

# Digital Output Gyro Sensor for Navigation

## Gyro sensor principles and features of the digital output gyro sensor XV4001 Series

### [Preface]

Gyro sensor measures angular rate, which is the rate of rotation per unit of time. There are three types of angular rate depending on the direction: yaw (horizontal rotation on a flat surface as seen when looking at a vehicle from above), pitch (vertical rotation as seen when looking at a vehicle from the front), and roll (horizontal rotation as seen when looking at a vehicle from the front). As the majority of vehicles are operated on flat surfaces the measurement of yaw, which provides the angle of horizontal curvature on a flat surface, is most commonly used. Gyro sensors are installed in the majority of modern navigation systems. In locations that do not allow for proper reception of a GPS (Global Positioning System) signal, including tunnels, parking garages and valleys in between buildings, an estimation-based piloting method referred to as DR (Dead Reckoning) is used to supplement positioning information from the GPS. Recently, we have seen numerous system configurations that use sensor signals as a primarily data source and use GPS to supplement sensor data. DR achieves a more precise navigation system by using angular data derived from the angular rate detected by gyro sensors combined with distance data calculated based on vehicle velocity pulses to measure vehicle position. With gyro sensors used in navigation systems, the output from the sensors during downtime, in other words when the system is not running, is vitally important. This is because angle data is calculated by integrating angular rate signals and thus output variations during downtime are factored into calculations and could lead to significant angle error.

As navigation systems are used in environments with extreme temperature variations, the temperature variation stability (temperature characteristics) of the gyro sensor output signal during downtime becomes a vital parameter. To achieve highly stable temperature characteristics, Epson manufactures and offers a digital output gyro sensor. This sensor is a complete package that combines a double-T structure crystal element, an AD converter that drives the sensor, amplifies the output signal, and converts the signal into a digital signal, and an IC with functions for corrective sensitivity, downtime output, and other attributes.

This White Paper features an explanation of Epson sensor technology, the temperature characteristics of digital output gyro sensors, and the digital interface.

### [Gyro sensor principles and structure]

#### 1. Principles of a vibration gyro sensor (Coriolis force)

Gyro sensors calculate angular rate by converting the rotation rate of the sensor into an electric signal. Epson applies the principle of the vibratory gyro, which is based on the vibration that occurs within the sensor. When rotational force occurring outside the sensor is applied to gyro vibration, the Coriolis force, which is generated in the direction that is perpendicular to the location of the vibration within sensor, produces a new vibration within the sensor. This new vibration is used to calculate the angular rate.

(The Coriolis force is a physical quantity first proposed by 19<sup>th</sup> century French physicist Gaspard-Gustave de Coriolis that indicates inertia at work on a rotating coordinate system. See Figure 1.)

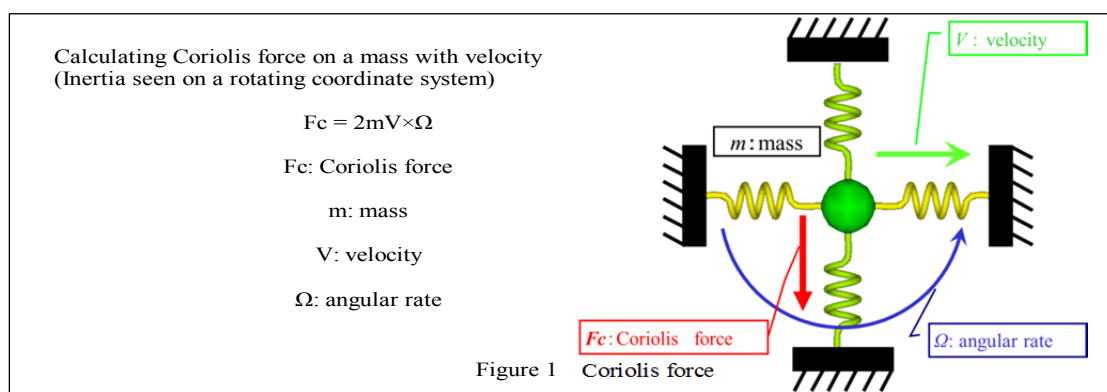



## 2. Gyro sensor principles (structure)

Epson gyro sensors use a crystal material for the internal vibrating element and are designed in a “Double-T Structure” that aligns two T-shaped crystals. The Double-T structure is symmetrical and, as shown in Figure 2, comprises “drive arm”, “sensing arm” and “stationary part” in the center.

During sensor operation, an alternating vibration electric field is applied to the drive arm to cause continuous lateral vibration. This causes the mutual cancellation of leaking vibration to achieve a sensing arm that remains static in the center (Figure 2 [1] – When either of the drive arms moves to the left, the opposing arm moves to the right. Because the motion of the left and right drive arms is symmetrical, no force is applied to the stationary part in the center and thus the sensing arm remains static). This makes it possible to maintain a stable point zero.

Next, when external rotational force is applied to the sensor, the Coriolis force is at work even as the left and right drive arms continue their symmetrical motion. This produces vibration in the perpendicular direction (Figure 2 [3]). As a result, the vertical vibration of the drive arm will cause one of the arms to move in the upward direction and the other arm to move in the downward direction. This vertical vibration of the drive arms will result in the application of rotational force on the stationary part. In turn, the rotation of the stationary part causes lateral vibration in the previously static sensing arm. Reading the vibration of the sensing arm as a change in the electrical charge allows the rotation applied to the sensor to be detected as angular rotation.

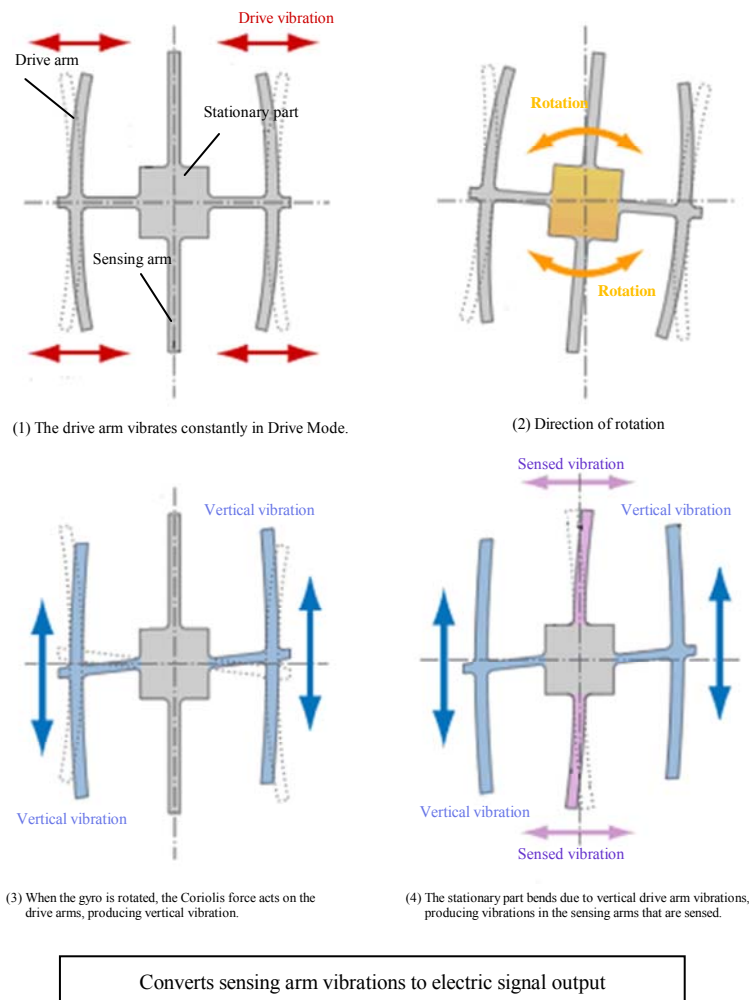

Figure-2 Gyro-sensor operating principles

3. Gyro sensor signal processing (signal processing of analog output gyro sensor)

Here, we provide an example of a basic gyro sensor (analog output) signal processing (Figure 3).

- (1) Oscillator circuit used to apply specific current and cause vibration of the drive arm
- (2) External rotational force (angular rate  $\omega$ ) works to cause Coriolis force and detect vibration in the sensing arm
- (3) Detected signal is amplified and wave form is corrected
- (4) Drive arm vibration phase is adjusted by  $90^\circ$  and compared with the vibration wave form of the sensing arm to calculate angular rate.

(With vibration of the sensing arm, different phase signals are output for the rotation angle  $-30^\circ$  (left direction  $30^\circ$ ) and  $30^\circ$  (right direction  $30^\circ$ ) rotation. As such, comparing this with the drive vibration wave form allows for the accurate calculation of the angular rate and direction of rotation.)

- (5) Output is adjusted and a voltage equivalent to the angular rate is output

Using the above process, the Coriolis force signal is separated from a micro detection signal and amplified and a voltage proportionate to the angular rate is output.

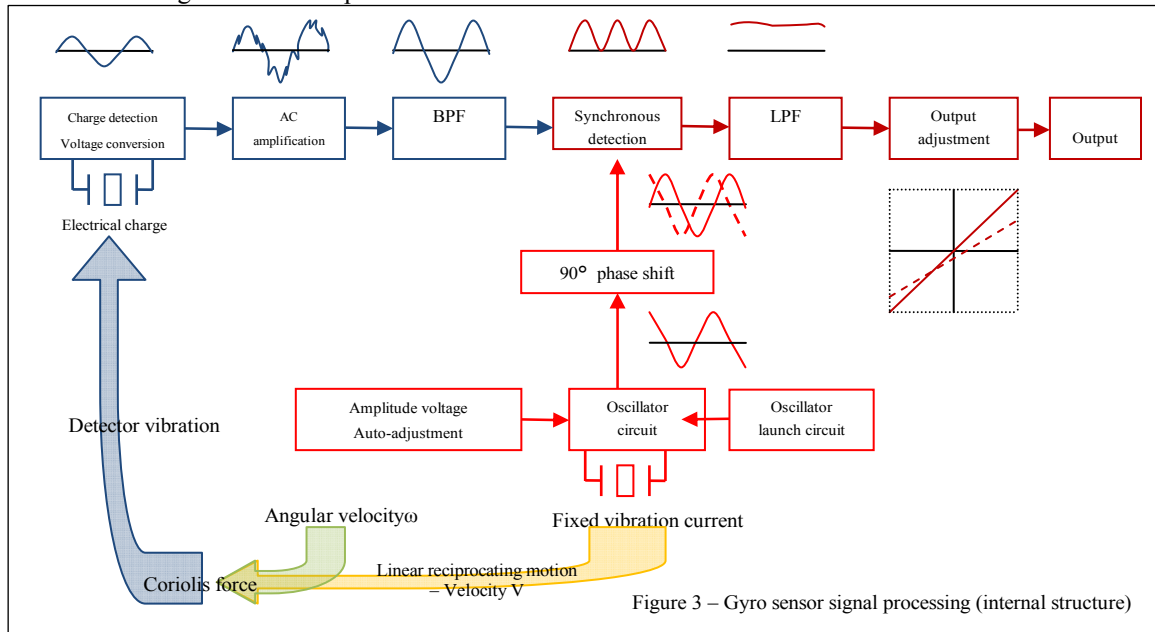

Figure 3 – Gyro sensor signal processing (internal structure)

[Digital output gyro functions & features]

Figure 4 shows a block diagram of the XV4001 series. An explanation of the product functions and the two compatible digital interfaces (SPI [4-wire, 3-wire], I<sup>2</sup>C) is provided below.

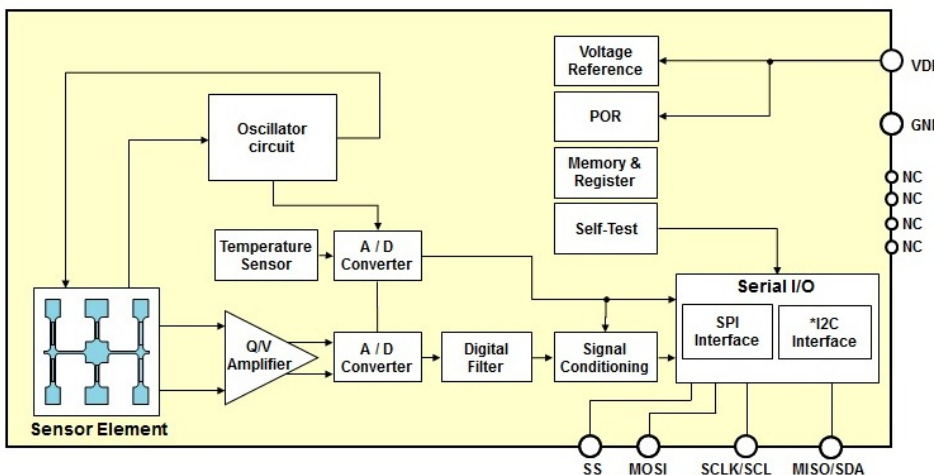

Figure 4 - Block diagram of the XV4001 series (digital output gyro)

## Functions

- Angular rate output: Output angular data are 16 bit and 2's complements.
- Digital filter: Built in the  $f_c=10\text{Hz}$  digital low pass filter.
- Temperature sensor: Output temperature data are 11 bit and 2's complements.
- Power On Reset (POR): Built in the Power On Reset (henceforth, POR) circuit. A POR signal required for initialization of a logic circuit at the time of power supply starting is outputted.
- Self-test: Built in the self test circuit. A self test implementation result is transmitted in a communication response (DIAG).

## Digital interface

### - SPI (4-wire, 3-wire)

Compatible with a maximum communication frequency of 10 MHz. Includes command error judgment and check-sum functions to ensure communication quality. Also includes a self-test function that detects errors within the gyro sensor. Test results are sent together with either the angular rate or temperature sensor output frame. The results of this test enable the determination of sensor errors.

### - I<sup>2</sup>C

Compatible with up to 400 kbit/s Fast Mode. The slave address configuration is 1101000 (sub-address = 1101001). (Configuration of the sub-address can be done prior to factory shipment.) Issuing the self-test judgment results output command provides the results of the self-test.

Figure 5 shows an example for when connecting the gyro sensor to a microcontroller.

With conventional analog output gyro sensors, signal sampling through an AD converter required the insertion of a specific filter circuit between the gyro sensor and the AD converter to prevent aliasing (folding noise). In comparison, the XV4001 series uses a digital interface that allows the gyro sensor signals to be sent directly to a microcontroller with no need for an AD converter to mediate gyro sensor output. Furthermore, the XV4001 series provides compatibility for bus connections (the ability to connect multiple devices on a single signal line), which makes wiring easier compared to conventional analog output gyro sensors.

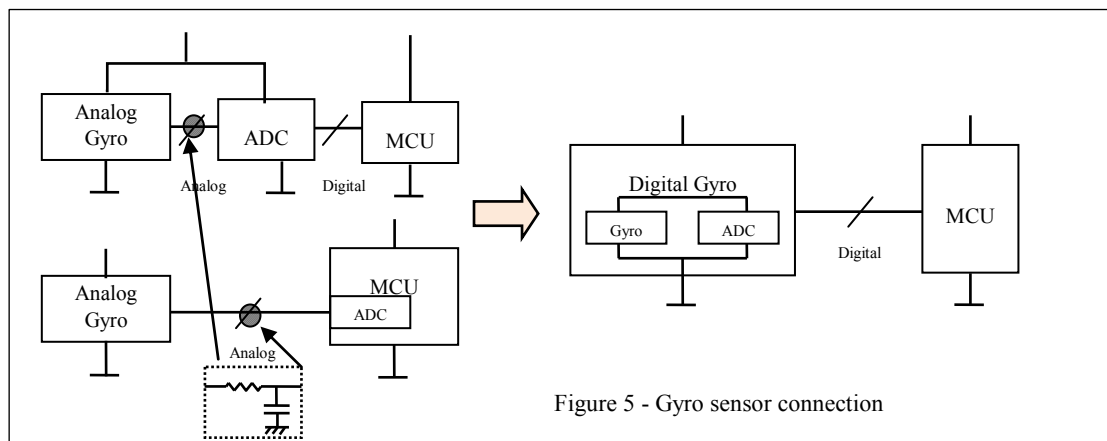

Figure 5 - Gyro sensor connection

### [VX4001 series gyro sensor features (temperature characteristics)]

Ideally, output from a static gyro sensor (when no angular rate is being applied) should be non-fluctuant. However, because navigation systems integrate angular rate output by the gyro sensor, fluctuations in angular rate output can have a significant impact on precise positioning information calculations. There are various causes of discrepancies in angular rate output but the primary cause is thought to be variations in temperature. The temperature characteristics of output from a static gyro sensor without temperature correction are shown in Figure 6.

Epson gyro sensors use quartz crystal for the sensor element. As such, even when temperature correction is not applied, it is clear that the angular rate output is a minor fluctuation. However, temperature characteristics trends and the rate of fluctuation will vary with each sensor element.

Some navigation systems internally make corrections for the temperature characteristics of gyro sensor angular rate output. However, due to the technical difficulty and cost-related constraints related to attempting to achieve temperature corrections for unique temperature characteristics trends and discrepancies for every operating temperature range, there has been a growing need for a gyro sensor with highly stable compatibility for angular rate output temperature characteristics. To meet this demand, Epson incorporated a digital correction circuit to provide advanced temperature correction during static output. Figure 7 shows the static output temperature characteristics of the Epson gyro sensor that conducts temperature correction using a digital correction circuit.

Through the application of high-order temperature compensation, the Epson gyro sensor achieves stable static angular rate output temperature characteristics and are improved the variation significantly over wide operating temperatures, from -40 °C to +85 °C.

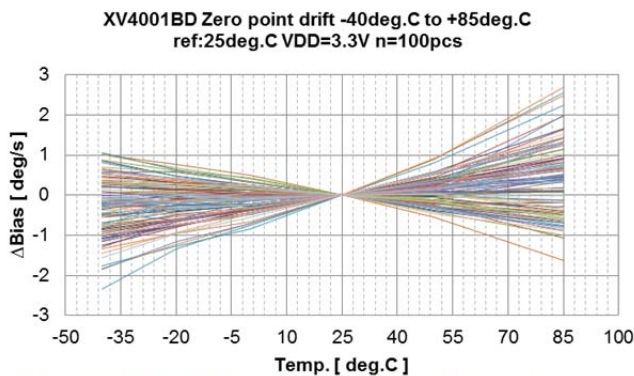

Figure 6 – Static output temperature characteristics before correction

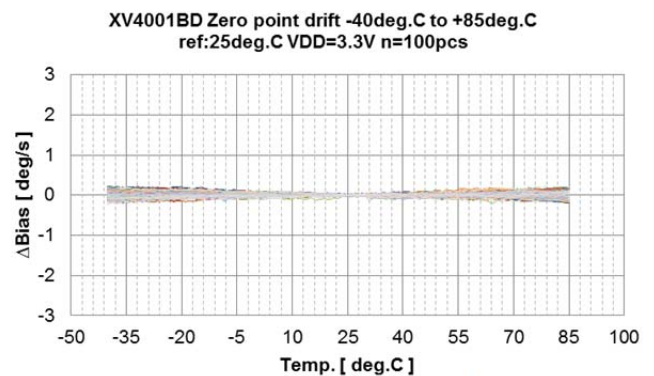
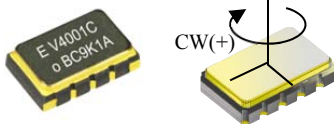
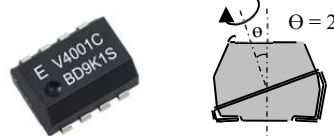

Figure 7 – Static output temperature characteristics after correction

Lastly, Table 1 shows the features and an overview of the VX4001 series.

The VX4001 series offers a packaged high-performance digital output gyro sensor providing the stability, connectivity to a microcontroller, interface compatibility, and installation angle versatility to make them optimal for use in navigation systems. With the VX4001 series, Epson will continue to contribute to increasing customer design optimization and product quality.

Table 1 VX4001 series overview

Product	Features	Interface	Size [mm] <sup>*1</sup>
XV4001BD	- Operating temp. range: -40 °C to +85 °C - Voltage: 3.3 V ±0.3 V	SPI (4-wire, 3-wire)	BD/BC: 5.0 x 3.2 x 1.3 mm (10 pin) 
XV4001BC	- Sensitivity: 370 LSB ±1.5 % (Ta = +25 °C) - Angular rate output: ±2 °/s (0 LSB typ.) (Ta = +25 °C) - Angular rate output temp. characteristics: ±1 °/s Typ.	I <sup>2</sup> C bus	
XV4001KD	- Detection range: ±70 °/s - Frequency bandwidth: 10 Hz Typ. - Power consumption: 3.5 mA Typ.	SPI (4-wire, 3-wire)	KD/KC: 6.0 x 4.8 x 3.3t (8 pin) 
XV4001KC	- Output noise: 0.05 °/s RMS Typ. - Equipped with temperature sensor - Equipped with self-test function	I <sup>2</sup> C bus	

\*1 – Two packages compatible with navigation installation angle (0°, 20°) - BD/BC and KD/KC